

1. Introduction

Module **A-198** is a so-called **Trautonium** resp. **Ribbon Controller**. It provides variable Control Voltages and Gate signals generated by combined **position / pressure sensor**. The controlling element of the A-198 is a **linear position sensor** (length about 50 cm) that has available a **pressure sensor** too.

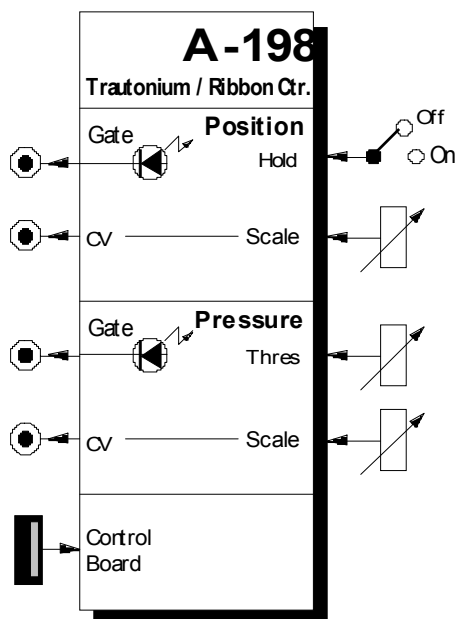

Touching the sensor with a finger generates a **Control Voltage** that is **proportional to the position of the finger**. The **Scale** - i.e. the relation between position difference and voltage difference - is **adjustable** with a potentiometer at the front panel. A **Hold** switch is used to determine if the CV voltage is held after removing the finger or if the voltage jumps to 0V. In the last case (Hold = off) a **Gate** signal is derived from the CV voltage whenever a finger touches the sensor (e.g. for triggering an Envelope Generator / ADSR).

A **pressure sensor** made of conductive rubber arranged below the position sensor generates a **second Control Voltage** that increases with higher pressure of the finger. Even for this CV the **Scale** is **adjustable**. A **second Gate** signal is triggered as soon as the pressure exceeds a certain value. The **Gate Threshold** is **adjustable** at the front panel.

2. Trautonium/Ribbon - Overview

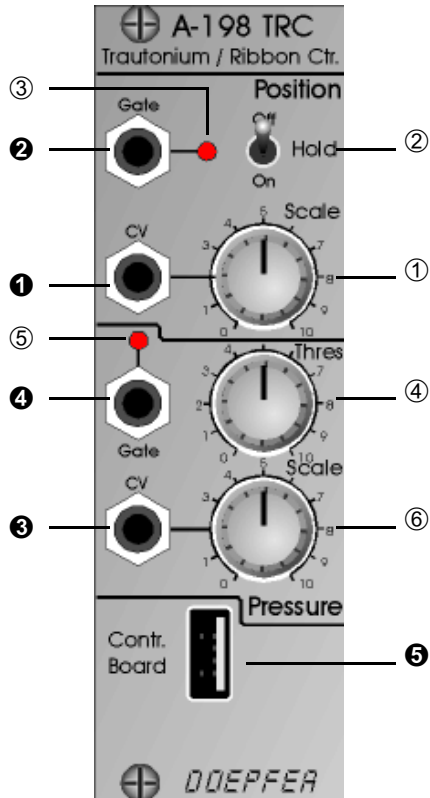

Controls:

- ① **Scale** : Scale / spread control for Position Control Voltage output ①
- ② **Hold** : Hold function switch
- ③ **LED** : Gate signal indicator for Position Gate at output ② (active only if Hold = off)
- ④ **Thres** : Threshold control for Pressure Gate signal at output ④
- ⑤ **LED** : Gate signal indicator for Pressure Gate at output ④
- ⑥ **Scale** : Scale / spread control for Pressure Control Voltage output ⑥

In / Outputs:

- ① **CV** : Position Control Voltage output
- ② **Gate** : Position Gate output (active only if Hold = off)
- ③ **CV** : Pressure Control Voltage output
- ④ **Gate** : Pressure Gate output
- ⑤ **Contr. Board**: Connector for manual (USB type)

⚠ Do not connect USB devices to this socket!

3. Controls

① Scale

The position sensor of the A-198 is in principle a linear potentiometer that is activated whenever a finger touches the sensor. Consequently the **relation** between the **position of the finger** and the **Control Voltage CV_{POS}** is **linear** too (see fig. 1).

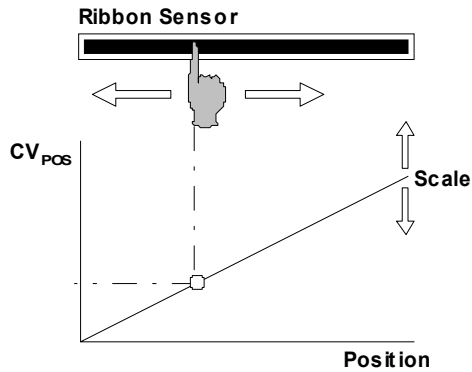

Fig. 1: Connection between position, Control Voltage CV_{POS} and Scale

The **Scale**, i.e. the connection between position difference and voltage difference, is adjusted with control ① (see fig. 1).



If CV_{POS} is used to control the VCO pitch the scale is adjusted with control ① so that the position difference corresponds to the desired spread, e.g. 25 cm for one octave.

② Hold

This switch determines the **behaviour** of the position control voltage CV_{POS} if the **finger is removed** from the sensor:

Off : CV_{POS} drops to 0V and the **Gate** output ② turns from high to low. This is the same mode that was available in the Trautonium.

On : The last control voltage before the finger was removed is held with an internal S&H circuit. In this mode the **Gate** function at output ② is not active (Gate is permanently high). This mode was not available in the Trautonium.

In the Off position of the Hold switch the control voltage CV_{POS} drops to 0V as soon as the finger is removed. If the Gate output ② is used to trigger an Envelope Generator (e.g. A-140, A-141), that controls the loudness of a VCA or the timbre of a VCF, the Release time of the Envelope Generator should be set to zero so that the dropping tone is muted. This is identical to the behaviour of the Trautonium. Even for

the Trautonium the sound disappears immediately if the finger is removed (no release).

③ LED

The LED ③ monitors the **Gate** signal at output ② that is triggered by touching the position sensor (active only in the Off position of the Hold switch).

④ Thres

Control ④ is used to set the **Trigger Threshold** above which a Gate signal is generated (see fig. 2). Whenever the pressure control voltage exceeds the threshold the Gate output ④ turns to high.

⑤ LED

The LED ⑤ monitors the **Gate** signal at output ④ that is generated whenever the pressure control voltage exceeds the threshold adjusted with control ⑤.

⑥ Scale

The pressure **Scale**, i.e. the connection between pressure and the voltage CV_{PRES} generated at output ③, is adjusted with control ⑥.

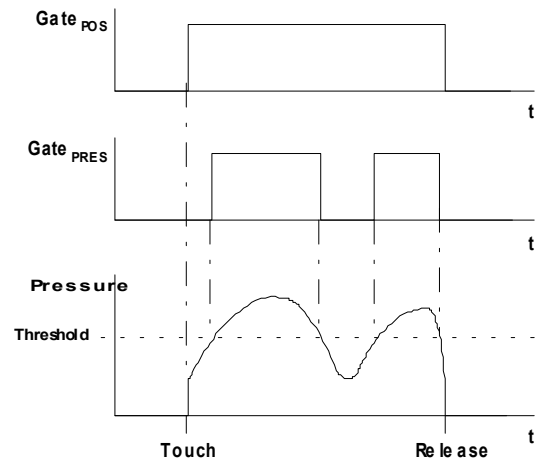

Fig. 2: Connection between the Gate signals and the finger pressure (Gate_{POS} is shown for Hold = Off)

The pressure sensor is made with conductive rubber and does not work as accurate as the position sensor. The resistance of the conductive rubber changes with varying pressure and causes a variable voltage. But the coherence between pressure and resistance/voltage is not very accurate - except that an increasing pressure will cause an increasing voltage. Even some difference of the pressure sensor behaviour over the length of the manual may be possible as the conductive rubber has tolerances over this length.

4. In- / Outputs

① CV

The **position dependent Control Voltage** CV_{POS} is available at this output.

② Gate

The **position dependent Gate signal** $Gate_{POS}$ is available at this output (active only in the Off position of the Hold switch).

③ CV

The **pressure dependent Control Voltage** CV_{PRES} is available at this output.

④ Gate

The **pressure dependent Gate signal** $Gate_{PRES}$ is available at this output. Whenever the pressure control voltage exceeds the threshold adjusted with control ④ the Gate output ④ turns to high.

⑤ Contr. Board

The **position and pressure sensors** are located in a separate metal frame. The connection between the module and the sensor frame is made by a 4 pin cable (same connectors and cable as used for USB connections). Socket ⑤ is used for the junction cable to the sensors. The junction cable and the metal frame that contains the sensors is included with A-198 manual.



It is not allowed to connect any USB device to socket ⑤ ! The USB device connected to the socket and the A-198 module will be destroyed and the warranty for both devices is void !

5. User Examples

In the first place module A-198 and the accessory position/pressure sensor is used to emulate the manual of the **Trautonium**. For details concerning the principles of the Trautonium please look at our web site www.doepfer.com or other web sites that deal with the Trautonium subject. In combination with the Sub-harmonic Oscillator A-113, the Trautonium Formant Filter A-104 and some other modules a complete reproduction of Oskar Sala's **Mixtur Trautonium** is possible.

Another evident application is the usage as a **manually controlled voltage source** that generates two continuously variable analog voltages and two gate signals that are derived from these voltages. Here are some typical examples:

- **CV_{POS} as Pitch CV for one or more VCOs**

Unlike a normal keyboard - that has only certain voltages (normally 1/12 V grid) and consequently only certain frequencies (semitones) available - the A-198 manual outputs a infinitely variable voltage CV_{POS} that allows any VCO frequency, especially finger-controlled glide effects and vibratos. By means of the Quantizer A-156 it is possible to generate semitone, scale or other intervals if desired. Moving the finger up and down the position sensor arpeggio-like effects are possible.

The gate signal **Gate_{POS}** that is generated whenever the position sensor is touched (hold switch in the Off position) an envelope generator (ADSR) can be triggered. The Release control of the ADSR should be set to zero (see remark on pages 3/4).

- **CV_{PRES} as "After Touch"**

CV_{PRES} can be used to control the loudness of a VCA or the filter frequency of a VCF with the pressure applied to the pressure sensor while CV_{POS} drives the pitch of the VCO(s).

- **CV_{POS} and CV_{PRES} as any controller**

Both control voltages CV_{POS} and CV_{PRES} can be used to control any parameter in the A-100 that is voltage controlled, e.g. phase or frequency shifting (A-125/A-126), panning (A-134), morphing (A-144 + A-135), pulsewidth (any VCO), LFO speed (A-147). The modulation intensity (e.g. the amplitude modulation of a VCA, frequency modulation of a VCF or VCO, pulse width modulation of a VCO) can be controlled by CV_{POS} and CV_{PRES}. For this the signal level of a LFO or VCO is controlled by a VCA whose control voltage is CV_{POS} or CV_{PRES}. Another application is to add another sound (e.g. noise or sampler or second VCO) dependent on CV_{PRES}.

- **Gate_{POS} and Gate_{PRES} as "Event Controller"**

The Gate signals can be used to trigger events, e.g. starting or stopping the Analog/Trigger Sequencer A-155 or switching between sound sources by means of the Voltage Controlled Switch A-150.

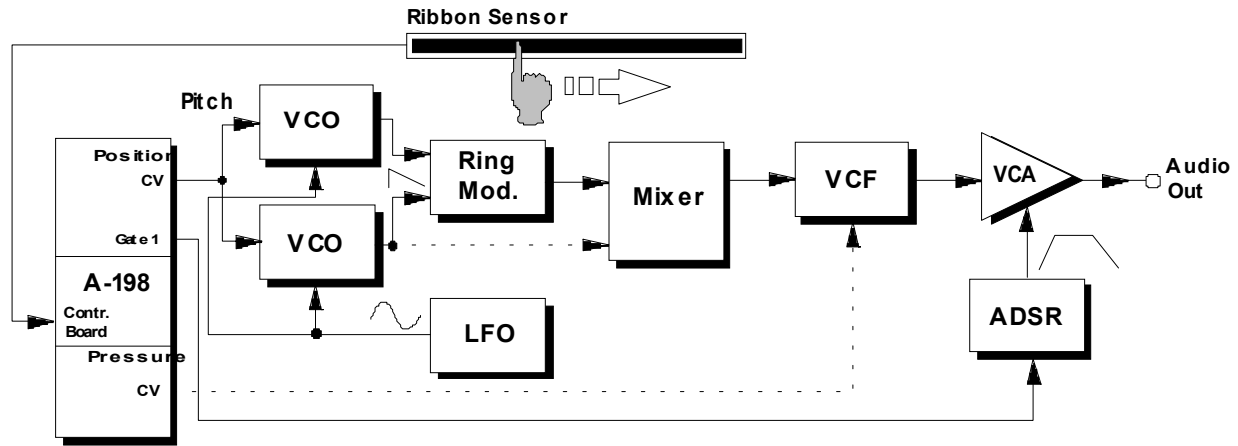

Fig. 3: "Sound of a hand passing over a wineglass"



By means of the CV-to-MIDI Interface **A-192** the output voltages of the A-198 can be converted into any **MIDI Controller** (for details see A-192 user's manual).

The patch in fig. 3 simulates the sound of a hand passing over a wineglass. The position control voltage defines the pitch of the VCOs. The position gate signal triggers the ADSR that controls the loudness progress of the sound.

With the ring modulator and suitable settings of the mixer, LFO frequency, filter frequency and resonance the typical bell-like sound is generated. The LFO provides the vibrato. Optionally the filter frequency can be controlled by the pressure voltage.

With different settings of the mixer and the filter metallic sounds are generated. In combination with fast envelopes one obtains percussive sounds that remind of hitting or plucking a string.

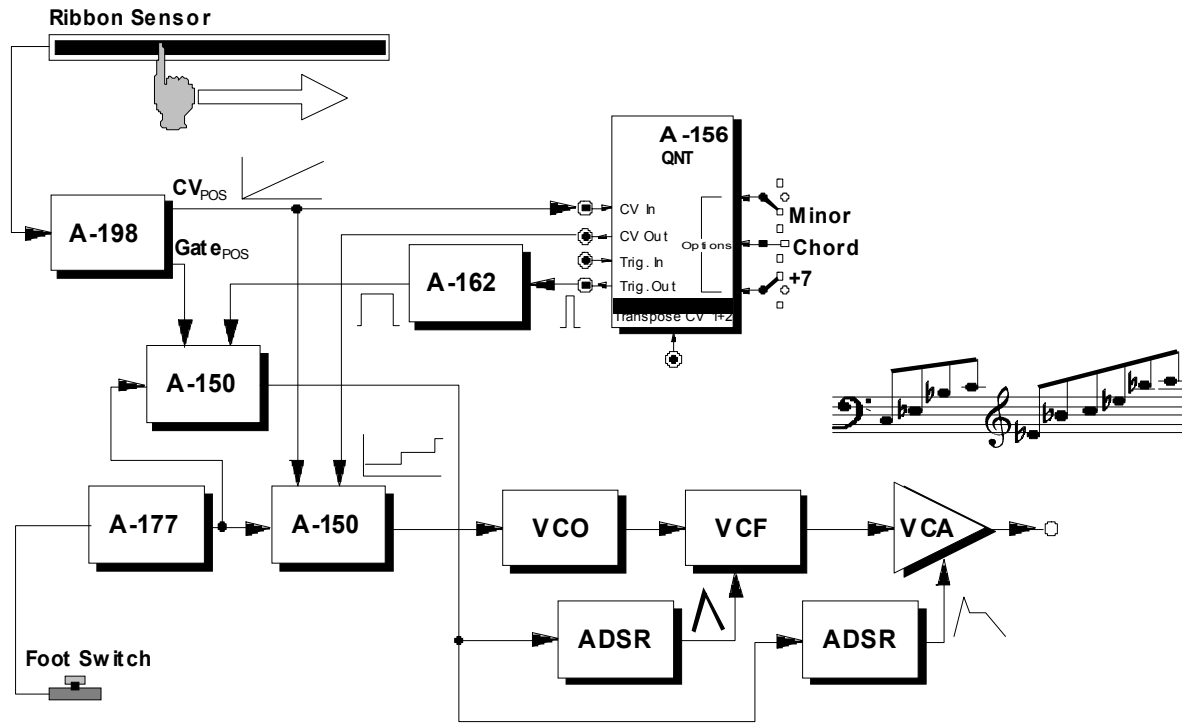

Fig. 4: A-198 as a "keyboard"

The patch of fig. 4 shows the application of the A-198 as a "keyboard". A foot switch in combination with the A-177 is used to select between quantized and non

quantized operation. The first of the two voltage controlled switches of the A-150 defines if the position voltage CV_{POS} is fed directly to the VCO or if CV_{POS} is quantized with the A-156. The setting of the quantizer determines if all semitones or only tones of the minor/

major scale or notes of a chord are allowed. For details please refer to the A-156 manual.

The second of the two voltage controlled switches of the A-150 module defines if the position gate $Gate_{POS}$ or the trigger output of the quantizer is fed to the gate input of the ADSR. Additionally a Trigger Delay A-162 is used to lengthen the short trigger signal coming out of the A-156.

Summary:

- Without quantizer each touch of the position sensor generates a gate signal $Gate_{POS}$ that triggers the ADSR for filter and loudness.
- In the quantized mode the A-156 generates short trigger signals (~ 10 ms) at each new quantization. These short pulses are expanded to the desired length by means of the Trigger Delay A-162. The output of the Trigger Delay triggers the ADSR for filter and loudness.

The patch can be extended in manifold ways:

- Feeding a keyboard or sequencer pitch control voltage to the transpose input of the quantizer (see fig. 4) transposes the sounds played on the A-198.
- Use the pressure voltage CV_{PRES} and the pressure gate $Gate_{PRES}$ for additional modulations (e.g. filter frequency, pulse width modulation, frequency modulation of VCO or VCF, VCF-ADSR or third ADSR triggered by $Gate_{PRES}$, third ADSR may be used to control modulation depth or frequency of a VCLFO for modulations).

You may add even additional controllers, e.g.

- Pitch: Position sensor (A-198) or Theremin (A-178)
- Frequency modulation (VCO): Pressure sensor (A-198)
- Filter frequency: Light controller (A-179) or Position sensor (A-198) or Pressure sensor (A-198)
- Glide on/off: Foot switch (A-177)
- Loudness: Theremin (A-178) or Foot controller (A-177)

6. Patch-Sheet

The following diagrams of the module can help you recall your own **Patches**. They're designed so that a complete 19" rack of modules will fit onto an A4 sheet of paper.

Photocopy this page, and cut out the pictures of this and your other modules. You can then stick them onto another piece of paper, and create a diagram of your own system.

Make multiple copies of your composite diagram, and use them for remembering good patches and set-ups.



- Draw in patchleads with colored pens.
- Draw or write control settings in the little white circles.

